

Owner's Manual

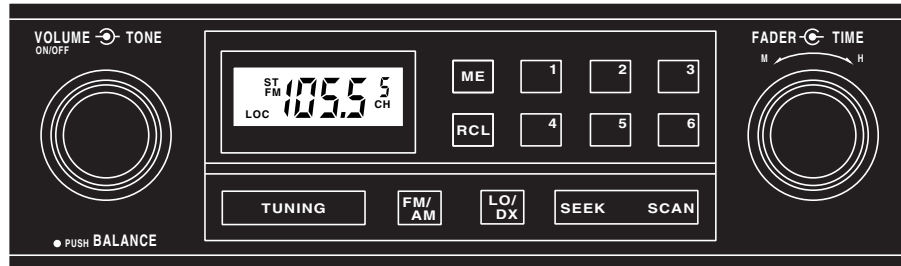

**AM/FM Stereo Receiver with Digital Clock,
Seek / Scan / Manual Tuning**

Model PPC-200

CONTROLS AND OPERATIONS

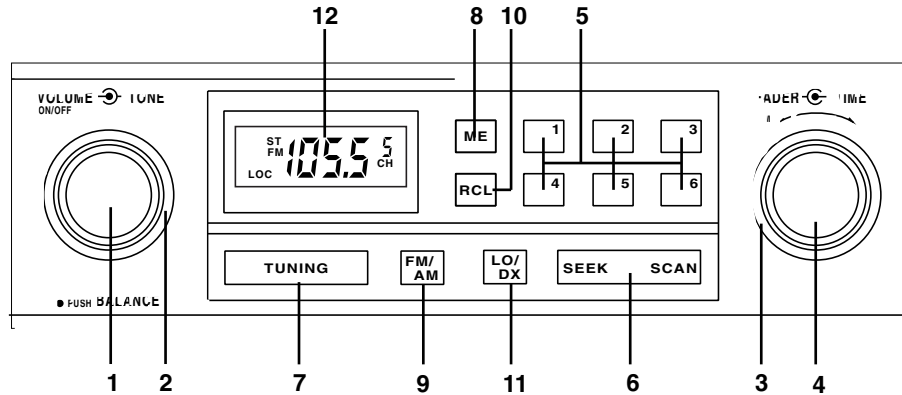

On / Off / Volume / Balance / Control Knob (1)

To turn the unit on, rotate the the volume control knob to the right. To adjust the the volume level, continue rotating the knob to the right. To turn the unit off, rotate the knob to the left until it clicks. Push in on the volume knob and rotate the knob from left to right to change the relative output of the left and right speakers. Adjust the balance control to your listing preference.

Tone Control Knob (2)

Rotating the tone control knob from right to left will adjust the overall tone quality higher or lower. Make the tone adjustment to your desired preference.

Fader Control Knob (3)

Rotating the fader control knob from left to right will change the relative output level of the front or rear speakers. Adjust the fader control to your listening preference.

Time Set Control Knob (4)

The time set control knob is used in conjunction with the memory button (ME) to set the clock. Please refer to the “how to set the clock” section of this manual for further details.

Station Recall Buttons (5)

The station recall buttons are used in conjunction with the memory (ME) button to memorize desired radio stations and recall them. (See the “How to Preset Radio Stations” section of this manual for further details)

CONTROLS AND OPERATIONS

Seek/ Scan Button (6)

Pressing the seek button will cause the tuner to search out the next strongest station up the tuning scale. To continue seeking, you must repeatedly press the seek button each time the tuner stops on a station.

Pressing the scan button will put the tuner into scan mode. When in the scan mode, the tuner will seek up to the next strongest radio station and stop for eight seconds. After 8 seconds the tuner will again seek up to the next strongest stations and hold for 8 seconds. To stop the scan mode, simply press the scan button once again and the tuner will stop scanning.

Manual Up / Down Tuning (7)

To manually tune a station up or down the scale, simply press the the up or down side of the manual tuning button. Hold the button down until you get close to the station and release it. Fine tune by pressing the button repeatedly.

Memory Button (8)

The memory button is used with the station recall buttons and the clock set button to program radio stations and set the clock. (See “how to set the clock and how to preset radio stations” for more details)

FM/AM Select Button (9)

Repeated pressing of the FM/AM button will change the tuner from FM1 band to FM2 band and to AM operation. The particular band will be displayed in the display area. Select the band you wish to listen to by repeated pressing of the FM/AM button.

Recall Button (10)

Pressing the recall button will change the display from the radio frequency to the clock. If you want to see the time in the display, simply press the recall button and the clock will appear for 5 seconds.

Local Distant Button (11)

Switch the LO/DX button to the LO position to prevent strong local stations from overlapping weaker stations. For normal operation and maximum sensitivity, switch to the DX position.

Note: When in the LO mode, “LOC” will be displayed in the display area.

Multi-Function LCD Area (12)

The LCD display area will indicate the following operating functions:

- * Radio frequency and clock time.
- * FM1, FM2 and AM1 radio bands.
- * Local radio reception mode and last preset memory button pushed.

Display Priority

The priority of the PPC-200 display area is dedicated to the radio frequency. If the recall button is pushed to see the time, the display will always change back to the clock after 5 seconds.

How to Set the Time

Repeat the following procedures to properly set the clock time.

1. Turn on the unit by rotating the volume control knob to the right.
2. Press the recall button to turn the display from the radio frequency to the clock mode.
3. Press and release the memory button while the clock time is displayed in the LCD area, the time showing will begin to flash.
4. While the display is flashing, rotate the time set control knob to the left to adjust the time and to the right to adjust the minutes.
5. Once the correct time is showing in the display, let the display change back to the radio station before turning the unit off.

CONTROLS AND OPERATIONS

How to Preset Radio Stations:

Repeat the following procedures to memorize radio stations:

1. Turn on the unit by rotating the volume control knob to the right.
2. Select the radio band (FM1, FM2, AM1) you want to memorize radio stations in by pressing the FM/AM button.
3. Use the manual tuning button to select a radio station you want to set into memory.
4. Press the memory button (ME) and release it. A "CH" indicator will begin to flash in the display area.
5. Press the station recall button you want that station memorized on (1-6).
6. Select the next band (FM1, FM2, AM1) and repeat steps 3,4 and 5 to memorize radio stations on all bands.

INSTALLING THE RADIO

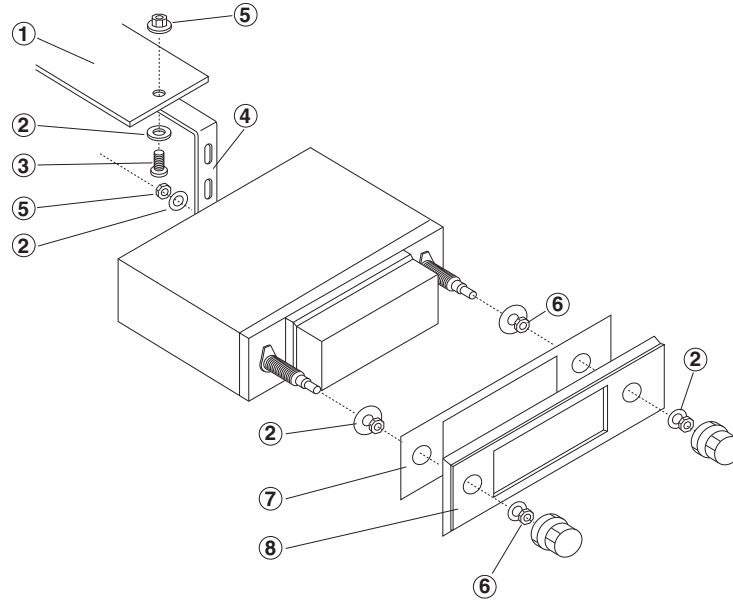

1. Anchoring Board
2. Flat Washer
3. Machine Screw
4. Mounting Strap
5. Hex Nut
6. Shaft Nut
7. Dashboard
8. Trim Plate

Installing the Radio

1. Locate the factory supplied opening for the radio or choose a location within reach of the primary operator of the vehicle.
2. Cut and file the opening if necessary so the shafts and the nosepiece of the radio will slide through the opening.
3. Place the spacing nuts and washers on the shafts and adjust them so that the nosepiece and shafts stick through the mounting far enough for the face plate to be positioned and held into place using the remaining nuts and washers. If the face plate is not used, adjust the radio depth so that the knobs will fit and operate smooth and correctly.

4. Support the rear of the chassis using the perforated back strap and nuts supplied. Attach the back strap to the rear chassis of the radio and find a secure, solid location to attach the end of the back strap.

Note: Reluctance to use or properly install the back strap will result in damage to the shafts and will cause the nosepiece to become distorted.

ELECTRICAL CONNECTIONS

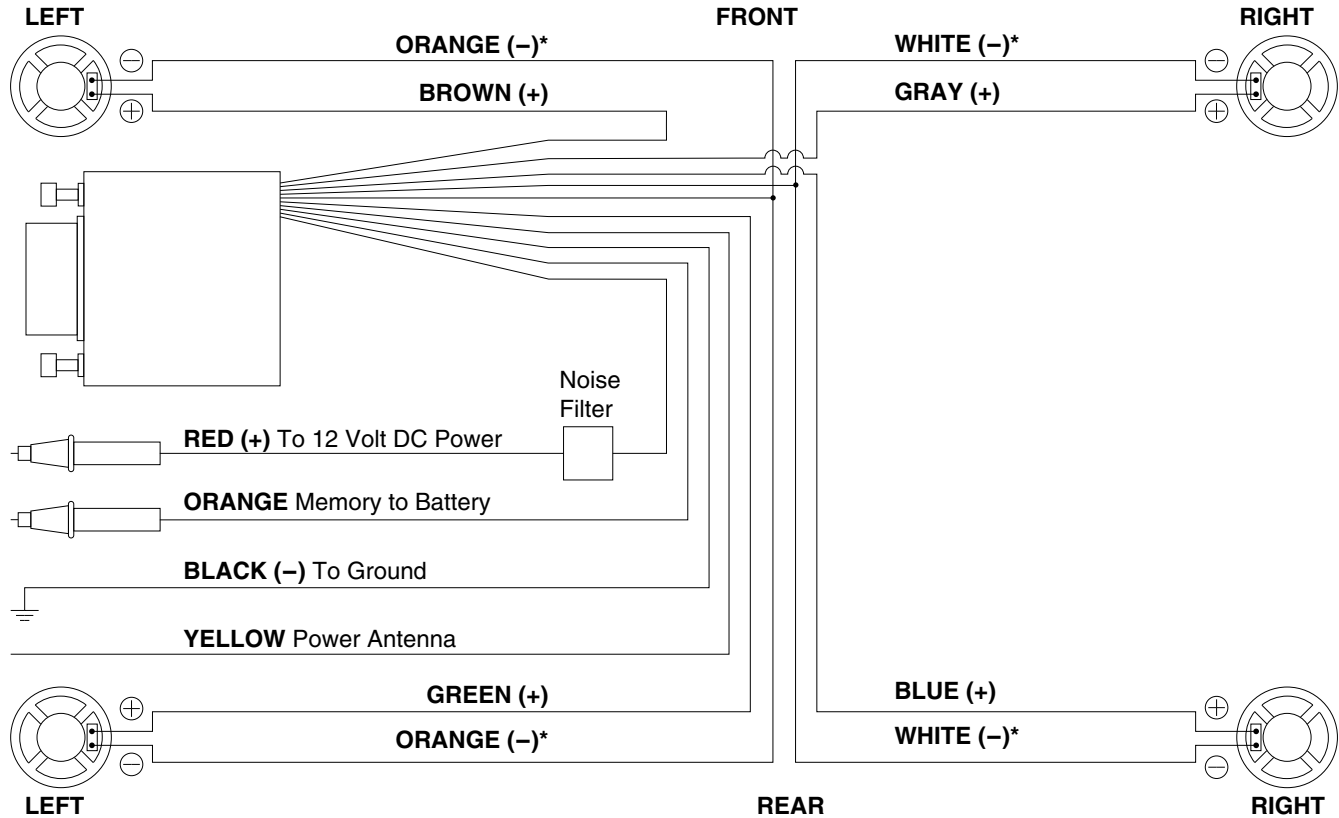

ELECTRICAL CONNECTIONS

Red Wire: (with fuse holder and noise filter)

Connect the red wire to a +12 volt power source that is “switched on and off by the ignition key. Most power sources can be located at the vehicles fuse block. Use a test light or volt meter to select the correct connection point.

Orange Wire: (with fuse holder)

Connect the orange wire to a constant +12 volt power source. The fuse block of the vehicle will provide a good connection point. Use a test light or volt meter to locate the proper point of connection. If a proper connection point can not be found at the fuse block, connect the orange wire directly to the (+) post on the battery.

Yellow Wire:

The yellow wire will provide +12 volts when the on/off control of the radio is switched to on. The yellow wire is used to trigger a power antenna relay. Connect the yellow wire to the positive trigger wire of the power antenna relay.

Black Wire:

Connect the black wire to the frame of the vehicle. Crimp a ring terminal to the black wire and use a nut a bolt to secure it to the vehicle chassis. A good ground is essential for proper performance of the PPC-200 unit.

Brown Wire:

Connect the brown wire to the positive terminal of the left front speaker.

Gray Wire:

Connect the gray wire to the positive terminal of the right front speaker.

Green Wire:

Connect the green wire to the positive terminal of the left rear speaker.

Blue Wire:

Connect the blue wire to the positive terminal of the right rear speaker.

White Wire:

Connect the white wire to the negative terminals of all speakers used for the right channel.

Orange Wire:

Connect the orange wire to the negative terminal of all speaker used for the left channel.

Note: In the wiring diagram there is more than one white and orange wire show. This is for clarification of connection of the white and orange wire. There is only one white wire and one orange wire provided on the harness.

SPECIFICATIONS

FM Tuner

Range	87.5 - 107.9MHz
Usable Sensitivity	17dBf (2uV)
50dB Quieting Sensitivity	23.2dBf (4uV)
Signal to Noise Ratio	60dB
Stereo Separation (@ 1kHz)	35dB
Capture Ratio	2.5dB
Alternate Channel Selectivity	65dB

AM Tuner

Range	530-1620kHz
Sensitivity (20dB Quieting)	10uV
Signal to Noise Ratio (@50uV)	42dB

Audio Section

Maximum Power Output	2 x 9 Watts
Continuous Average Power Output (rms) 10% THD	2 x 5.5 Watts
Power Supply Voltage (Negative Ground)	14.4 Volts DC

Dimensions

Chassis	178mm (W) x 44mm (H) x 130mm (D)
Nose Piece	105mm (W) x 42mm (H) x 130mm (D)
Weight	1.2kg

WARRANTY

ONE (1) YEAR LIMITED WARRANTY

Magnadyne Corporation or its authorized agents will within 1 year from the date of sale to you, repair, replace or refund the retail sales price of said product or any part thereof, at the option of the Magnadyne Corporation or its authorized agents, if said product or part is found defective in materials or workmanship, when properly connected and operating on the correct power requirements designated for the specific product. This warranty and Magnadyne Corporation or its authorized agents obligations hereunder do not apply where the product was; damaged while in the possession of the consumer, subjected to unreasonable or unintended use, not reasonably maintained, utilized in commercial or industrial operations, or serviced by anyone other than Magnadyne Corporation or its authorized agents, or where the warning seal on the product is broken or the power and/or plugs are detached from the unit. Magnadyne Corporation or any of its authorized agents will not assume any labor costs for the removal and re-installation of any product found to be defective, or the cost of transportation to Magnadyne Corporation or its authorized agents. Such costs are the sole responsibility of the purchaser.

This warranty does not cover the cabinet appearance items or accessories used in connection with this product, or any damaged to recording or recording tape, or any damage to the to the products resulting from improper installation, alteration, accident, misuse, abuse or acts of nature.

MAGNADYNE CORPORATION OR ITS AUTHORIZED AGENTS SHALL NOT BE LIABLE TO ANYONE FOR CONSEQUENTIAL OR INCIDENTAL DAMAGES OR CLAIMS EXCEPT THOSE ACCORDED BY LAW. NO EXPRESSED WARRANTY OR IMPLIED WARRANTY IS GIVEN EXCEPT THOSE SET FORTH HEREIN. NO IMPLIED WARRANTY SHALL EXTEND BEYOND 1 YEAR FROM THE DATE OF SALE.

This warranty extends only to the original purchaser of the product and is not transferable.

Some states do not allow limitations on how long an implied warranty lasts, and some states do not allow the exclusion or limitation of incidental or consequential damages, so the above limitations or exclusion may not apply to you. This warranty gives you specific legal rights, and you may have other rights that vary from state to state.

Defective merchandise should be returned to the original point of purchase or secondly, to Magnadyne Corporation, 1111 W. Victoria Street, Compton CA 90220, or 2061 Cohen Street, Montreal, Quebec H4R 2N7. Return Authorization must be obtained before sending, or merchandise may be refused.